



**SPORTSMAN**

*Owner's Manual and  
Quick-Reference Guide*



## WELCOME TO THE SPORTSMAN TEAM!

Here at Sportsman Boats, we take great pride in producing the finest, most well designed saltwater fishing and pleasure boats on the market today. Our designs incorporate the most modern technology while applying good old “Common Sense” technology as well. From our advanced composite construction, ergonomic console designs, patented “Total Access” hatch, and superior ride and handling characteristics, we think you will agree that Sportsman is setting a new standard. Sportsman Boats builds the fastest growing line of family-friendly center console boats in-class, built with the latest designs, procedures and materials to give you and your family unparalleled performance with a dry, safe and comfortable ride

We do not take lightly the confidence you have placed in us with your decision to purchase your Sportsman boat. We will always strive to provide for you and your family the superior customer service you deserve. We hope that you enjoy your time out on the water as much as we enjoy building your Sportsman boat!

Safe Boating and Tight Lines,  
*Tommy Hancock*

# SPORTSMAN

---

# Important Information



<b>BOAT INFORMATION / SPECIFICATIONS</b>	
MODEL:	HULL SERIAL #:
PURCHASE DATE:	DELIVERED:
IGNITION KEY #:	REGISTRATION #:
DRAFT:	WEIGHT:
VERTICAL CLEARANCE:	
<b>ENGINE / PROPELLER INFORMATION</b>	
ENGINE MAKE:	MODEL:
ENGINE SERIAL #:	
PROPELLER MAKE:	# OF BLADES:
DIAMETER / PITCH:	MODEL:
PART #:	
<b>OPTIONAL EQUIPMENT / OPTION PACKAGES</b>	
<b>TRAILER INFORMATION</b>	
MAKE:	MODEL:
SERIAL #:	GVRM:
ADDITIONAL INFORMATION:	
DEALER	SPORTSMAN
NAME:	PHONE:
PHONE:	REPRESENTATIVE:
SALES PERSON:	ADDRESS:
SERVICE MANGER:	
ADDRESS:	

We recommend filling out the information in this table and keeping one copy of this page in your personal records and one copy with your owner's manual. This information will be important should you need to contact your dealer or Sportsman Boats Manufacturing for technical assistance and/or service.

# Specifications



Length Overall	20'11"
Beam	8'5"
Draft	12"
Deadrise at Transom	15°
Approximate Usable Fuel Capacity	61 gal.
Approximate Dry Weight	2400 lbs.
People Capacity	10 persons
Maximum Engine Horse Power	200 HP (4 Stroke)

**SPORTSMAN**

# Overall Dimensions & Terminology

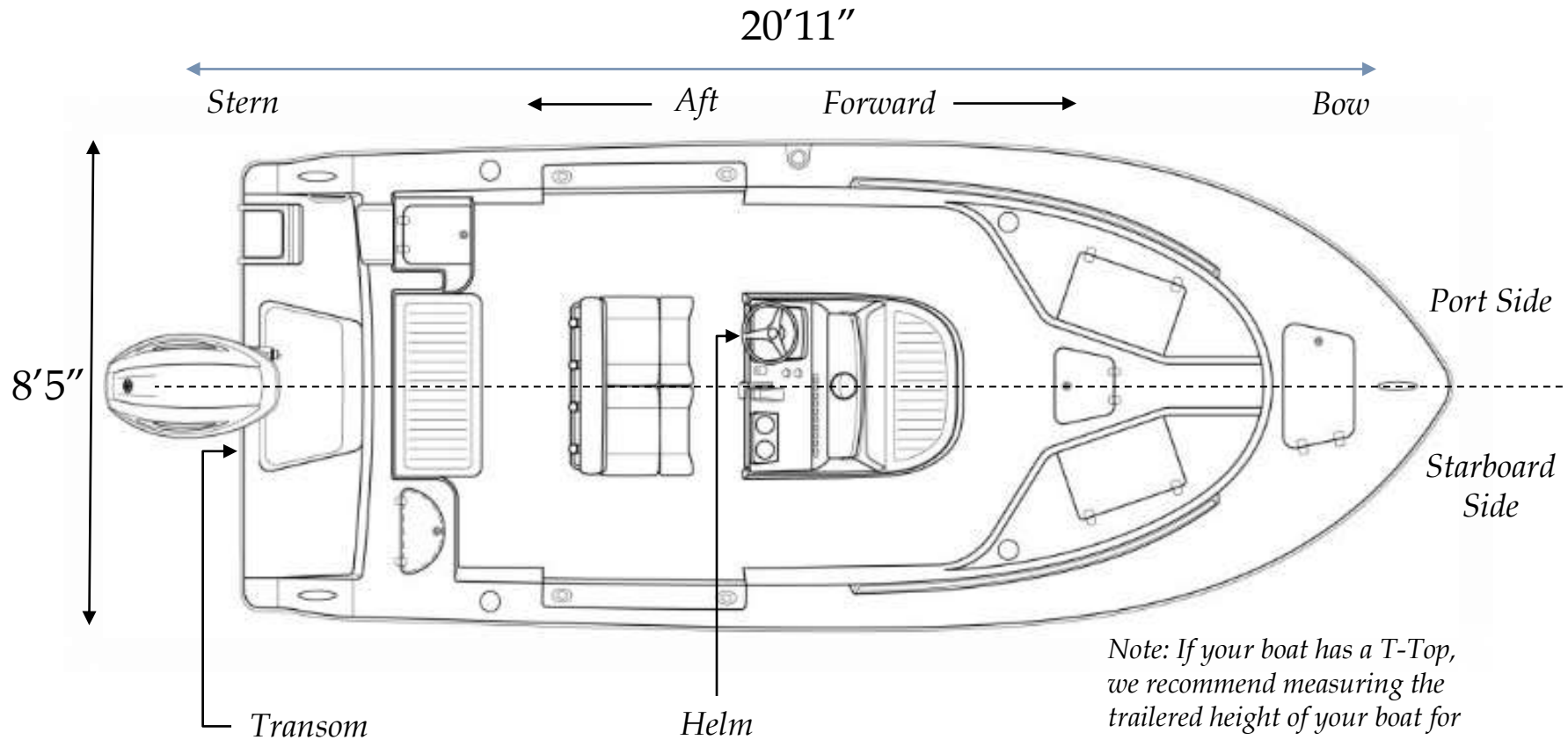

*Note: If your boat has a T-Top, we recommend measuring the trailered height of your boat for towing safety purposes. The approximate trailered height is 10'2". This height may depend on the specific trailer being used.*

# SPORTSMAN

# Features & Performance

## Standard



- SportTech™ Advanced Fabrication Process
- SportLink™ Electronics Integration System
- Garmin GPSMAP® 942xs MFD 9"
- Airmar B60 Thru-Hull Transducer
- JL Audio MediaMaster® MM50 Premium Marine Stereo
- (4) Fusion Audio RA670 White Sport Grille Speakers
- 10-Year Hull Warranty
- 25 Gallon Livewell w/ Livewell Pump
- 4 Flush Mount Gunwale Rod Holders
- 64 Gallon Fuel Tank w/ Fuel Level Sensor
- Advanced Fiberglass Stringer System (No Wood)
- All White Hull (Sides & Bottom)
- Anchor Storage
- Bow Cushion Set w/ Bolsters
- Built-In Swim Platform w/ 3 Step Ladder
- Cockpit Bolsters
- Console Footrest w/ Glove Box & Storage Bin
- Console Windscreen
- Dash Panel Cover
- Deluxe Leaning Post w/ Flip Up Bolsters
- Dual Battery Configuration w/ Switch & Trays
- Grip Tex Yacht Style Non-Skid
- High Speed Livewell Pick Up
- Horn
- Hydraulic Tilt Steering
- Insulated Bow Storage
- Interior LED Lighting Package
- JL Audio Combo USB & 3.5 mm Audio Jack
- Lockable Console Storage
- NMMA Certified
- Port and Starboard Toe Rail
- Premium Marine Vinyl with Distressed Look
- Pull-Up Cleats
- Raw Water Washdown
- Rear Fold Down Seat w/ Access
- Recessed Bow Hand Rails
- Removable Reclining Bow Backrest
- Rub Rail Navigation Lights
- Self Bailing Cockpit
- Stainless Steel Cup Holders - 8
- Stainless Steel Drain Covers
- Stainless Steel Propeller
- Stainless Steel Rub Rail
- Stainless Steel Steering Wheel w/ Knob
- Stainless Steel Switches
- Seakeeper Ride
- Under Gunwale Rod Racks
- Underlid Gasket

## Powder Coat Selection

- Black - White

## Color Selection

- Driftwood
- Ice Blue
- Island Blue
- Jet Black
- Sea Mist Green
- Silver Cloud
- Steel Blue
- White

# SPORTSMAN

# Features & Performance



## Options

- Second Garmin GPSMAP® 942xs MFD 9"
- Garmin VHF 110 Radio w/ Antenna
- Garmin GMR™ Fantom 18 Radome
- Garmin Reactor™ 40 Autopilot (req. EPS)
- Garmin GXM™ 53 SiriusXM® Weather Antenna
- Fusion/RA770/JL Amps Package
- Airmar B175M CHIRP Thru-Hull Transducer Upgrade
- Bimini Top
- Bow Filler Board w/ Cushion
- Compass
- Console Cover
- Custom Color Engine
- Dark Hull Color(Black/St Blue)
- Dark Hull Color(Black/St Blue) Upgrade
- Deluxe T-Top w/ LED Lighting
- Edson 13" SS Comfort Grip Steering Wheel w/ PowerKnob
- Fiberglass Hard-Top w/ LED Lighting
- Fiberglass Hard-Top w/ LED Lighting(Upgrade)
- Freshwater Washdown w/ 15 gal. Tank
- Gull Wings
- Gunwale Rod Holders / Each
- Helm Pad
- Yeti Cooler w/ Slide Out Track
- Light Hull Color
- Matching Hard-Top Underside Color
- Misters (Hard-Top only)
- Mooring Cover
- On-Board Battery Charging System
- Optimus Electronic Power Steering w/ Tilt
- Porta Potti
- Powder Coating
- Powder Coating for Ski Tow Bar
- Ski Tow Bar
- Spray Shield
- T-Top Cargo Net (Deluxe T-Top only)
- Table (Removable) w/ Mount - Bow
- Taco Outriggers - GS280
- Transhield Shipping Cover
- Under Leaning Post Tackle Storage
- Underwater Lights

# SPORTSMAN



# Features & Performance

## Major Features

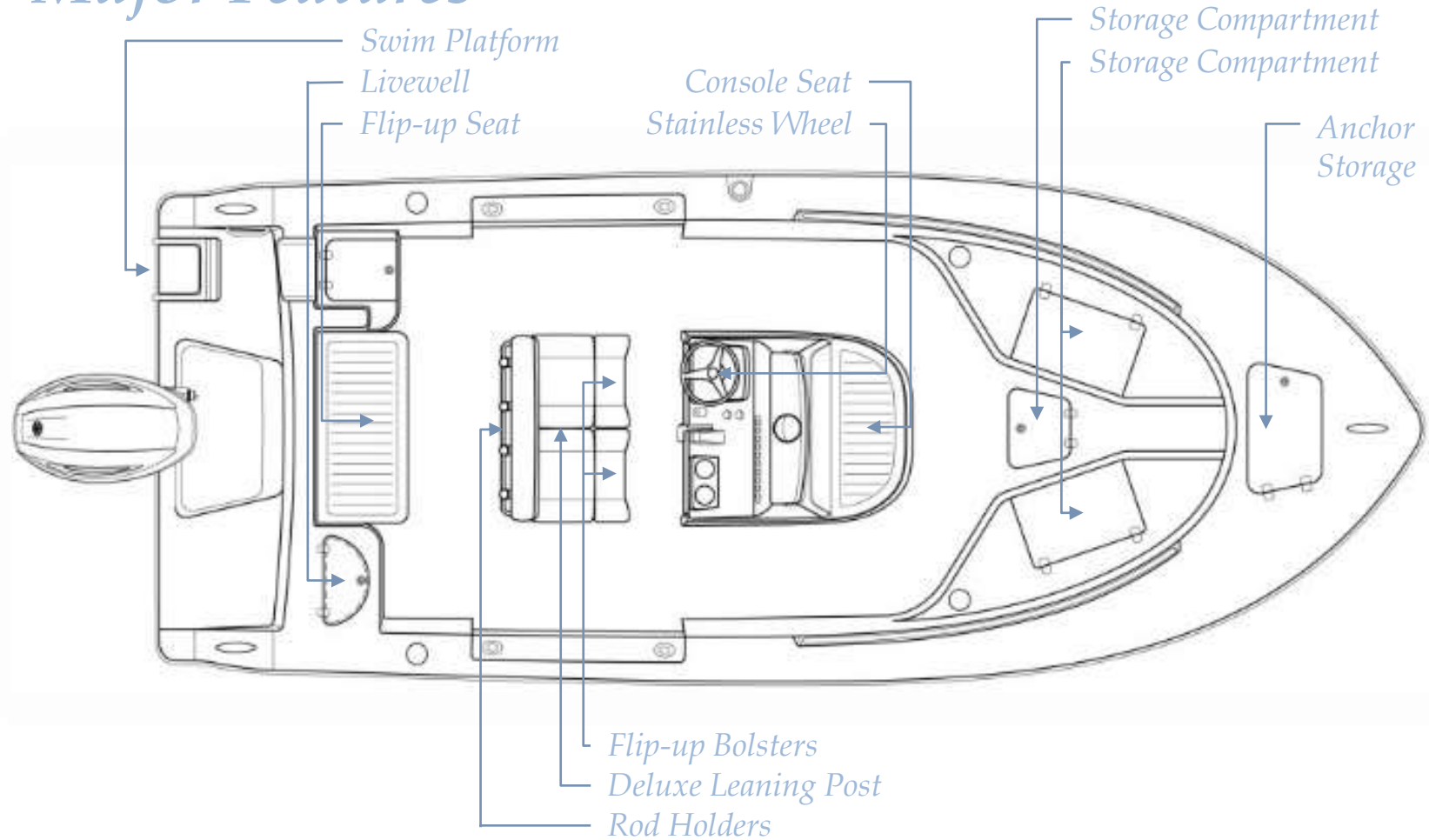

# SPORTSMAN



# Features & Performance



## 150 HP

## 200 HP

### PERFORMANCE BULLETIN

YPM# PH\_SPT\_Heritage211\_F150XA\_2013-12-06\_OCG



**SPORTSMAN**  
Boat Manufactured By:  
Sportsman Boats • PO Box 2100 • Summerville, SC 29486  
843-379-3628 • www.sportsmanboatsmfg.com

RPM	MPH	GPH	MPG
1000	4.7	0.8	5.69
1500	6.7	1.2	5.58
2000	9.1	2.0	4.05
2500	11.5	3.3	3.49
3000	19.2	4.1	4.68
3500	24.7	5.1	4.84
4000	29.1	6.7	4.34
4500	34.2	8.8	3.88
5000	39.3	11.3	3.39
5500	42.4	15.0	2.83
5850	45.8	18.5	2.78

Time to Plane: 3.55  
0-30 MPH: 5.18



© 2013 Yamaha Motor Corporation, U.S.A. All rights reserved.

**Sportsman® Heritage 211**

Length: 20' 11"  
Beam: 8' 5"  
Dry Weight (out on lift): 2,300 lbs  
Maximum HP: 150  
Fuel Capacity: 90 gal  
Weight as Tested: 1,441 lbs

**F150XA**

Horsepower: 150 HP @ 5000 RPM  
Induction: EFI  
Displacement: 163 cu. in.  
Weight: 401 lbs  
Gear Ratio: 2.00

**ENGINE MOUNTING HEIGHT**

Mounting Hole Position: #1  
Ventilation Hole Height: 1" Above Boat Bottom

**PROPELLERS**

Series: Reliance Series  
Diameter/Pitch: 14-1/4 x 18  
Yamaha Part #: SF-45975-00-00  
Propeller Material: Polished Stainless Steel

**TEST CONDITIONS**

Number of People: 2  
Air / Water Temperature (Fahrenheit): 62 / 67 F  
Elevation (in feet above sea level): Sea Level  
Wind Velocity: 0-3 mph

Comments: Test weight includes 12 lbs of fuel, 1 battery, water, and test gear.

Note to disclaimer: This information and data contained in this Performance Bulletin is approximate and is subject to many other factors and variables. It is provided as a guideline only and should not be used as an indicator of actual performance. Your boat's performance may be different than the information contained in this Performance Bulletin due to various factors, including your boat's actual weight, wind and water conditions, temperature, humidity, elevation, bottom type, boat loading, loading equipment and anchor load weight, and operator ability. Please confirm the specifications and performance data on your vessel's loadings configuration with your dealer prior to purchase. Please also keep in mind that the data contained in this Performance Bulletin may or may not have been performed using Yamaha Power-Assist components. Yamaha reserves the right to change the specifications and performance data of the Performance Bulletin at any time without notice. This document contains many of Yamaha's valuable trademarks. It may also contain trademarks belonging to other companies. Any references to other companies or their products are for identification purposes only, and are not intended to be an endorsement.

For more information:  
Yamaha Motor Corporation, U.S.A.  
One Dryden, Maine Street  
1205 Olden Road, 001  
P.O. Box 100, 001  
P.O. Box 100, 001  
P.O. Box 100, 001  
For other Performance Bulletins, visit our website at [www.sportsmanboatsmfg.com](http://www.sportsmanboatsmfg.com).

© 2013 Yamaha Motor Corporation, U.S.A. All rights reserved.

### PERFORMANCE BULLETIN

YPM# PH\_SPT\_Heritage211\_F200XB\_2013-07-11\_OCG



**SPORTSMAN**  
Boat Manufactured By:  
Sportsman Boats • PO Box 2100 • Summerville, SC 29486  
843-379-3628 • www.sportsmanboatsmfg.com

RPM	MPH	GPH	MPG
1000	5.1	0.8	6.38
1500	6.7	1.3	5.15
2000	9.8	2.0	4.15
2500	11.9	3.2	3.79
3000	20.2	4.2	4.81
3500	25.3	5.1	4.96
4000	30.0	7.0	4.40
4500	34.9	9.0	3.88
5000	39.3	13.4	2.93
5500	43.6	17.0	2.57
5900	47.8	19.8	2.41

Time to Plane: 4.00  
0-30 MPH: 5.00



© 2013 Yamaha Motor Corporation, U.S.A. All rights reserved.

**Sportsman® Heritage 211**

Length: 20' 11"  
Beam: 8' 5"  
Dry Weight (out on lift): 2,300 lbs  
Maximum HP: 200  
Fuel Capacity: 90 gal  
Weight as Tested: 1,440 lbs

**F200XB**

Horsepower: 200 HP  
Induction: EFI  
Displacement: 211 L  
Weight: 406 lbs  
Gear Ratio: 1.90

**ENGINE MOUNTING HEIGHT**

Mounting Hole Position: #1  
Ventilation Hole Height: 1" Above Boat Bottom

**PROPELLERS**

Series: Reliance Series-SDS  
Diameter/Pitch: 14-1/4 x 17  
Yamaha Part #: SF-45975-10-00  
Propeller Material: Polished Stainless Steel

**TEST CONDITIONS**

Number of People: 2  
Air / Water Temperature (Fahrenheit): 65 / 67 F  
Elevation (in feet above sea level): Sea Level  
Wind Velocity: 0-3 mph

Comments: Test weight includes 12 lbs of fuel, 1 battery, water, and test gear.

Note to disclaimer: This information and data contained in this Performance Bulletin is approximate and is subject to many other factors and variables. It is provided as a guideline only and should not be used as an indicator of actual performance. Your boat's performance may be different than the information contained in this Performance Bulletin due to various factors, including your boat's actual weight, wind and water conditions, temperature, humidity, elevation, bottom type, boat loading, loading equipment and anchor load weight, and operator ability. Please confirm the specifications and performance data on your vessel's loadings configuration with your dealer prior to purchase. Please also keep in mind that the data contained in this Performance Bulletin may or may not have been performed using Yamaha Power-Assist components. Yamaha reserves the right to change the specifications and performance data of the Performance Bulletin at any time without notice. This document contains many of Yamaha's valuable trademarks. It may also contain trademarks belonging to other companies. Any references to other companies or their products are for identification purposes only, and are not intended to be an endorsement.

For more information:  
Yamaha Motor Corporation, U.S.A.  
One Dryden, Maine Street  
1205 Olden Road, 001  
P.O. Box 100, 001  
P.O. Box 100, 001  
P.O. Box 100, 001  
For other Performance Bulletins, visit our website at [www.sportsmanboatsmfg.com](http://www.sportsmanboatsmfg.com).

© 2013 Yamaha Motor Corporation, U.S.A. All rights reserved.

Note: These bulletins are for the Heritage 211, but the 212 has the same performance. These are posted on our website at <http://sportsmanboatsmfg.com/heritage-211-center-console/>





## *NMMA Certification*

Sportsman Boats is certified by the National Marine Manufacturers Association (NMMA). NMMA certification not only meets the standards of the United States Coast Guard (USCG), but goes further to meet the standards set by the ABYC (American Boat and Yacht Counsel). All Sportsman models have been designed, constructed, and thoroughly tested to meet or exceed these standards. For more information about these standards, you may visit <http://www.nmma.org/certification/boats>.

## *Hull Identification Number & Registration*

Sportsman has a permanent record of your boat. This record is documented during the manufacturing process. It is identified by its "Hull Identification Number" (HIN). **The HIN is a 12-digit code located on the starboard side of the transom, just under the Rub Rail.** When contacting your dealer concerning maintenance or warranties, please have your HIN and model number available. This information can be found on your copy of the warranty card. Federal and State laws require a power boat to be registered in the state where it is primarily used. Registration numbers and validation stickers must be displayed according to regulations. The registration certificate must be on board when boating. The boat serial number, or Hull Identification Number (HIN), is required on the registration form. The HIN should be included on all documents or any correspondence.



## LIGHTING

Your Sportsman boat is equipped with navigation lights which comply with both Inland and International rules.

## FIRE EXTINGUISHER

At least one Type-1 hand held portable fire extinguisher must be carried on board. For boats over 20' two are required. Check extinguisher regularly for charge status.

## REQUIRED SAFETY EQUIPMENT

The US Coast Guard (USCG) requires that every boat have specific equipment on board. Check with local regulations on mandatory equipment apart from the list of Coast Guard requirements.

## SOUND SIGNALING DEVICES

Your Sportsman boat is equipped with an electric horn which meets the USCG requirements for a sound signal device.

## PERSONAL FLOTATION DEVICE (PFD)

You must have a USCG approved personal flotation device of Type I, II, or III aboard for each passenger, in addition to one Type IV throw able PFD. **Always wear a PFD when boating.** In some states, children are required to wear a PFD at all times. Check your local regulations.

## VISUAL DISTRESS SIGNALS

USCG approved visual distress signals are required for day and night use when operating on US waters. Approved signals include flares, orange smoke, an orange distress flag, or an electric distress light.



Being on the water is a great experience, but it can become a bad experience very quickly if safety and maintenance instructions of your boat are not followed. Therefore, warnings and notices have been included in order to help you operate and maintain your boat safely. They are defined as follows:

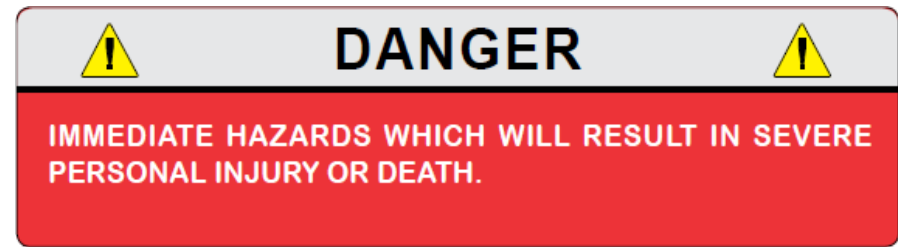
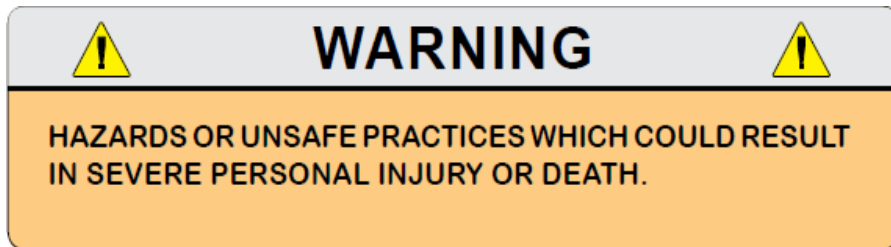

Please become familiar with the location and content of the Caution, Warning, and Danger Labels found on your boat.

# Boating Safety



Your Owner's Manual was written to include safety instructions to ensure safe operations. Safety alert symbols are used to show potential personal injury hazards.

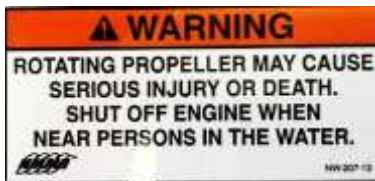
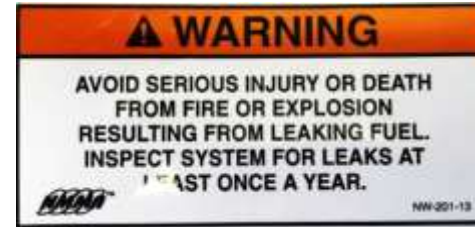

Every precaution has been taken to reduce the risks associated with death, possible injury and damage from fire or explosion. You must also take your own necessary precautions and practice proper maintenance procedures in order to enjoy the optimal safe operation of your boat.

*If your label is damaged. Please call Sportsman's parts department for replacement stickers.*

Your boat produces carbon monoxide and uses flammable fuel. Carbon monoxide can cause brain damage or death. Carbon monoxide is colorless, odorless and extremely dangerous.

**⚠ DANGER**



**Carbon monoxide (CO)** can cause brain damage or death.

Engine and generator exhaust contains odorless and colorless carbon monoxide gas.

Carbon monoxide will be around the back of the boat when engines or generators are running.

Move to fresh air, if you feel nausea, headache, dizziness, or drowsiness.

NW-206-13

**⚠ WARNING**

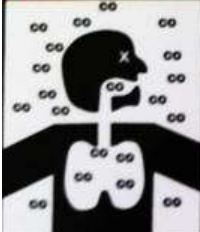

**Carbon monoxide (CO)** can cause brain damage or death.

Engine and generator exhaust contains odorless and colorless carbon monoxide gas.

Signs of carbon monoxide poisoning include nausea, headache, dizziness, drowsiness and lack of consciousness.

Get fresh air if anyone shows signs of carbon monoxide poisoning.

See Owner's Manual for information regarding carbon monoxide poisoning.

# Boating Safety Label Locations



**MAXIMUM CAPACITIES**  
**10 PERSONS OR 1800LBS.**  
 40 TO 100 LBS. PERSONS, MOTOR, GEAR  
 200 H.P. MOTOR

THIS BOAT COMPLIES WITH U.S. COAST GUARD SAFETY STANDARDS IN EFFECT ON THE DATE OF CERTIFICATION OR  
 MEETS U.S. EPA EVAP STANDARDS USING CERTIFIED COMPONENTS

MANUFACTURER: Sportsman Boats Manufacturing, Inc.  
 MODEL: Open 212 Summerville, SC

BOAT COMPLIANCE WITH NOAA REQUIREMENTS IS VERIFIED BY MANUFACTURER'S RESPONSIBLE PISH PRODUCTION CONTROL.

**NOAA CERTIFIED** NATIONAL MARINE MANUFACTURERS ASSOCIATION

**MEETS U.S. EPA EVAP STANDARDS USING CERTIFIED COMPONENTS**

Sportsman Boats Mfg. Summerville, SC

**⚠ WARNING**  
 ROTATING PROPELLER MAY CAUSE SERIOUS INJURY OR DEATH. DO NOT APPROACH OR USE LADDER WHEN ENGINE IS RUNNING.

**⚠ DANGER**

Carbon monoxide (CO) can cause brain damage or death.  
 Engine and generator exhaust contains odorless and colorless carbon monoxide gas.  
 Carbon monoxide will be around the back of the boat when engines or generators are running.  
 Move to fresh air, if you feel nausea, headache, dizziness, or drowsiness.

**⚠ WARNING**

Carbon monoxide (CO) can cause brain damage or death.  
 Engine and generator exhaust contains odorless and colorless carbon monoxide gas.  
 Signs of carbon monoxide poisoning include nausea, headache, dizziness, drowsiness and lack of consciousness.  
 Get fresh air if anyone shows signs of carbon monoxide poisoning.  
 See Owner's Manual for information regarding carbon monoxide poisoning.

**⚠ WARNING**  
 CONTENTS CAN BE UNDER PRESSURE. AVOID SERIOUS INJURY OR DEATH FROM FIRE OR EXPLOSION. OPEN SLOWLY IN WELL VENTILATED AREA. NO SMOKING OR OPEN FLAMES.

**⚠ WARNING**  
 AVOID SERIOUS INJURY OR DEATH FROM FIRE OR EXPLOSION RESULTING FROM LEAKING FUEL. INSPECT SYSTEM FOR LEAKS AT LEAST ONCE A YEAR.

**⚠ WARNING**  
 ROTATING PROPELLER MAY CAUSE SERIOUS INJURY OR DEATH. SHUT OFF ENGINE WHEN NEAR PERSONS IN THE WATER.

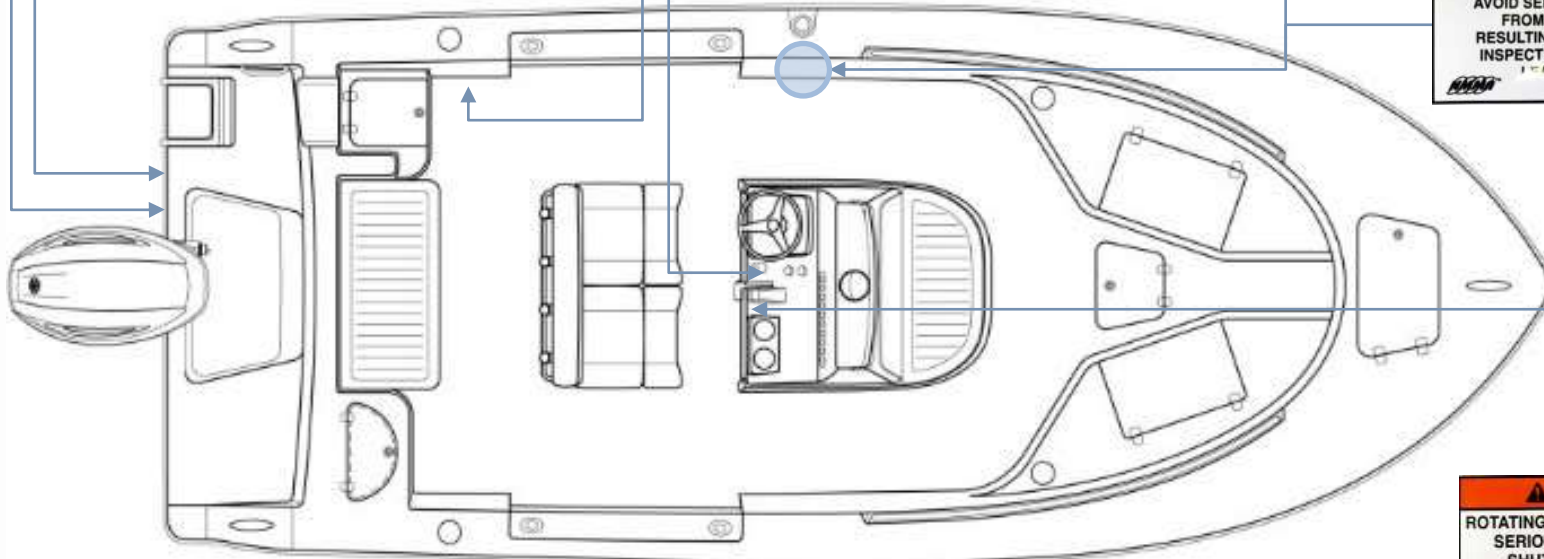

**SPORTSMAN**

# Boating Safety



The Sportsman Open 212 has a 10 Person Capacity. Seating locations are shown below.

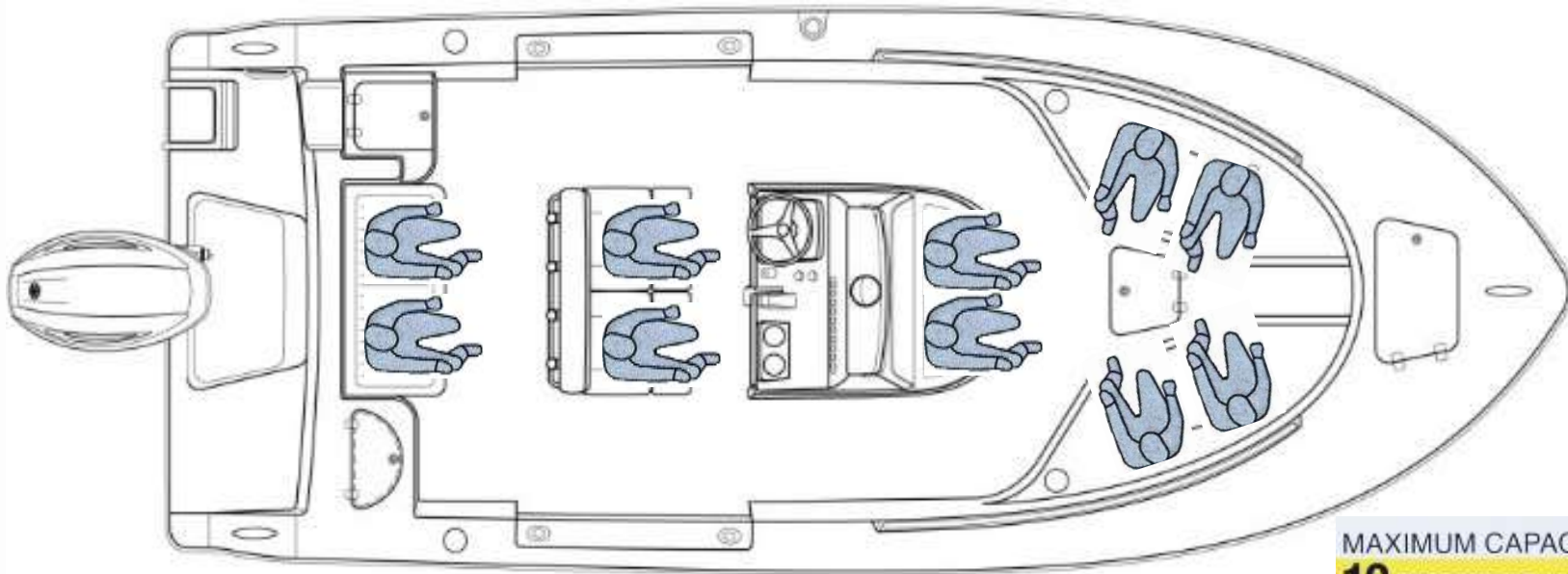

## MAXIMUM CAPACITIES

**10** PERSONS OR 1800 LBS.

4010 LBS. PERSONS, MOTOR, GEAR  
200 H.P. MOTOR

THIS BOAT COMPLIES WITH U.S. COAST GUARD SAFETY STANDARDS IN EFFECT ON THE DATE OF CERTIFICATION

MEETS U.S. EPA EWP STANDARDS USING CERTIFIED COMPONENTS

MANUFACTURER: Sportsman Boats Manufacturing, Inc.

MODEL: Open 212      Summerville, SC

DESIGN COMPLIANCE WITH NMMA REQUIREMENTS IS VERIFIED. MANUFACTURER RESPONSIBLE FOR PRODUCTION CONTROL.



NATIONAL MARINE MANUFACTURERS ASSOCIATION

# SPORTSMAN



## **Aquatic Invasive Species (AIS)**

Aquatic invasive species (AIS) are plants and animals that occur in waters in which they are not native and whose introduction causes or is likely to cause economic or environmental damage or harm to human health. AIS have a negative impact on the waterway, its native species, and recreational and commercial uses of the waterway.

As responsible boaters and citizens, each boat owner should do their part to prevent the spread of these aquatic hitchhikers. In many cases, it is also required by law. Check local regulations for any waterway where you will boat.

After each boating trip, follow these three simple steps before you leave the water access to stop the spread of AIS: Clean, Drain, and Dry. This is the boater's way to help protect the environment from the damage that AIS can cause.

### **Clean**

Inspect and remove all aquatic plants, animals, mud, and debris from the boat, engine, trailer, anchor, and any watersports equipment.

Rinse, scrub or wash, as appropriate, away from storm drains, ditches, or waterways.

Rinse watercraft, trailer, and equipment with hot water, when possible.

Flush motor according to owner's manual.

### **Drain**

Completely drain all water from the boat and its compartments, including but not limited to the bilge, wells, lockers, ballast tanks or bags, bait containers, engines, and outdrives.

### **Dry**

Allow the boat to completely dry before visiting any other bodies of water.

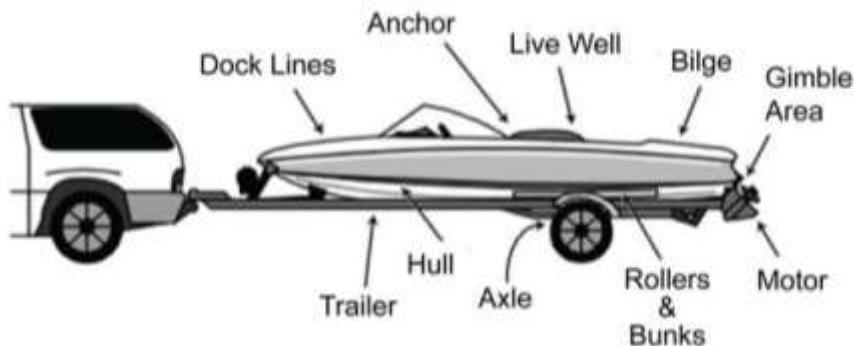

*NOTE: Some localities may require inspection or decontamination before and/or after launching. Check state and local laws and regulations for requirements prior to traveling to go boating.*

# Electrical & Plumbing Systems



## Wire Harness



Fuse Panel

The fuse panel is located under the console. It is clearly labeled for easy identification. The bilge pump's 6 amp fuse is also located here. There is also a 30 amp breaker branching off the main battery switch. If an electrical component of your boat stops working properly, this should be the first place to look.

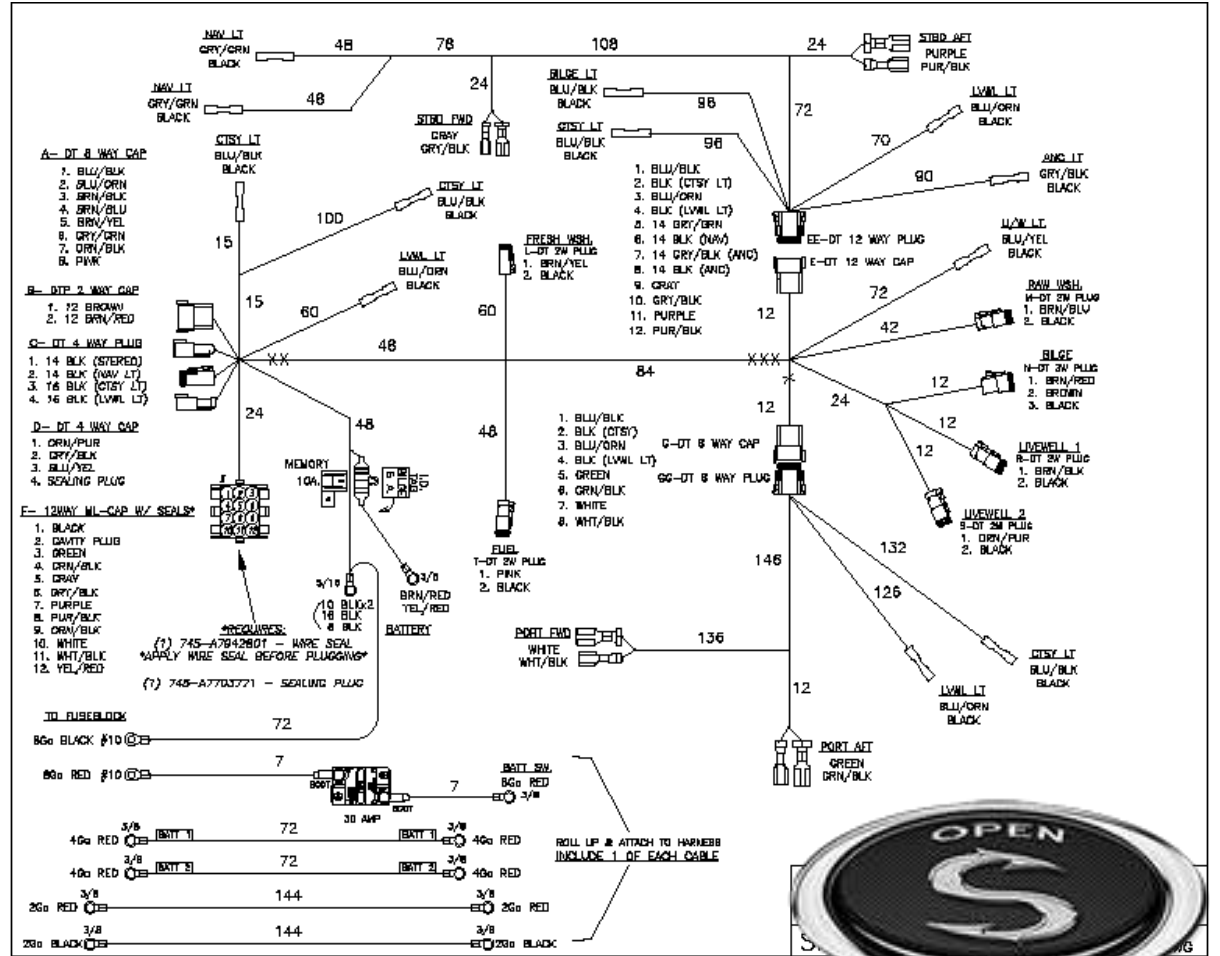



	1 1/2" HOSE-HELIX PN 100053
	1 1/2" HOSE-BLACK PN 100071
	1 1/2" HOSE-HELIX PN 101223
	COLLECTOR BOX PN 100052

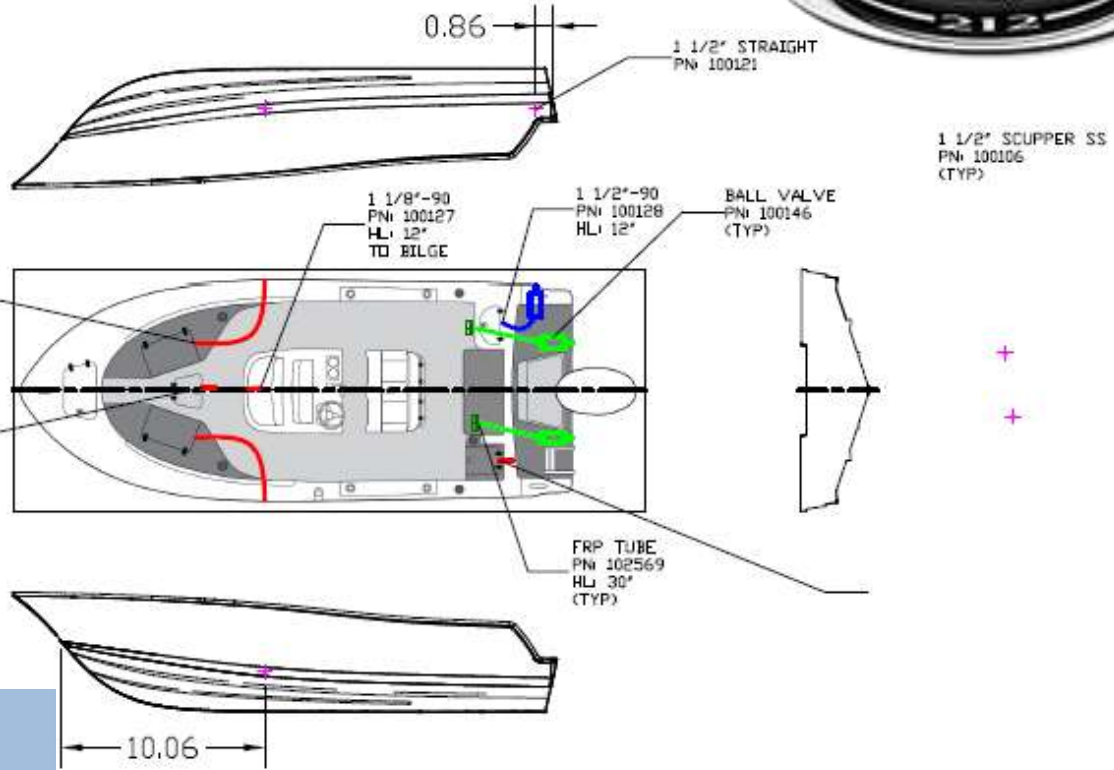

1 1/2" -90  
PN 100127  
HL 36"

1 1/8" -90  
PN 100127  
HL 12"  
TO BILGE

1 1/2" -90  
PN 100128  
HL 12"

BALL VALVE  
PN 100146  
(TYP)

1 1/2" SCUPPER SS  
PN 100106  
(TYP)

FRP TUBE  
PN 102569  
HL 30"  
(TYP)

# Electrical & Plumbing Systems

UNLESS OTHERWISE SPECIFIED		NAME	DATE	<b>SPORTSMAN</b>	
DIMENSIONS ARE IN INCHES TOLERANCES: FRACTIONAL ± 1/16" ANGULAR ± 0.5 deg	DRAWN	ABT	2/19	TITLE:  212 DRAIN HOSE ROUTING	
	CHECKED				
	ENG APPR.				
	MFG APPR.				
INTERPRET GEOMETRIC TOLERANCING PER	D.A.			SIZE	DWG. NO.
MATERIAL	N/A			A	212CT-CW*000
FINISH				SCALE: 1/8	WEIGHT:
DO NOT SCALE DRAWING	COMMENTS:				REV
					SHEET 1 OF 1

PROPRIETARY AND CONFIDENTIAL  
THE INFORMATION CONTAINED IN THIS  
DRAWING IS THE SOLE PROPERTY OF  
SPORTSMAN BOATS INC. ANY  
REPRODUCTION IN PART OR AS A WHOLE  
WITHOUT THE WRITTEN PERMISSION OF  
SPORTSMAN BOATS INC IS  
PROHIBITED.

# Electrical & Plumbing Systems



## **SportLink® Electronics Integration System**

*Take control of your electronics with SportLink® Electronics Integration System, equipped standard on every Sportsman Boat. The Garmin powered electronics packages have been carefully designed around each model to meet and exceed your needs out on the water.*



The Garmin 943 XSV is a great fit for your Sportsman. With a high definition scanning sonar, navigating mapping and coastal charts preloaded, and easy to build marine systems, the 943 XSV is a good choice to keep your center console connected.

# SPORTSMAN

# Electrical & Plumbing Systems

## Garmin 9" Package

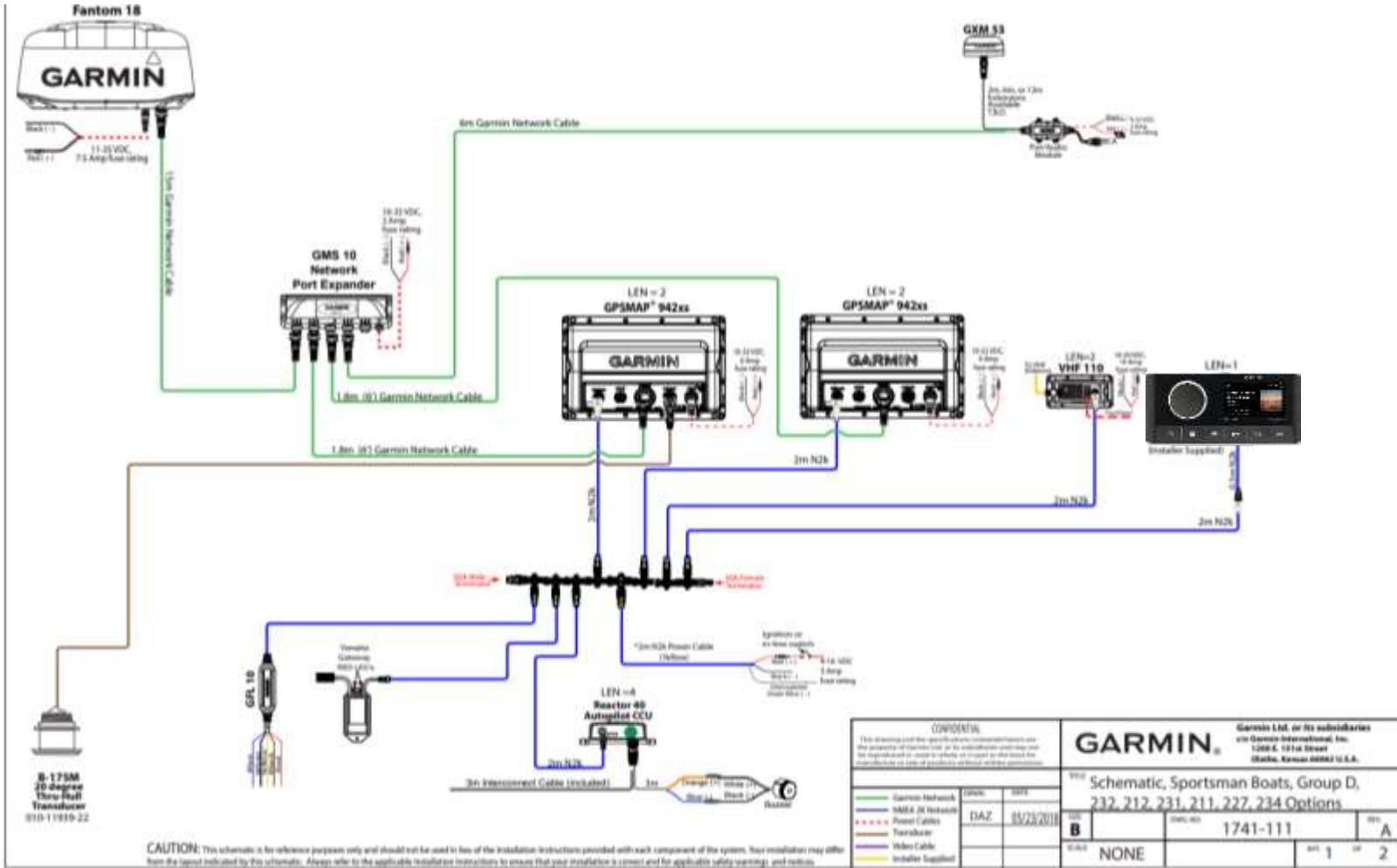

<p><b>CONFIDENTIAL</b></p> <p>This drawing and the specifications herein are the property of Garmin Ltd. or its subsidiaries and may not be reproduced or used in whole or in part without the written consent of Garmin Ltd. or its subsidiaries.</p>		<p>Garmin Ltd. or its subsidiaries  <b>GARMIN</b>                  1200 E. 101st Street                  Olathe, Kansas 66061 U.S.A.</p>	
<p>Legend:</p> <ul style="list-style-type: none"> <li>Green line: Garmin Network</li> <li>Blue line: NMEA 20 Network</li> <li>Red line: Power Cables</li> <li>Black line: Transducer</li> <li>Yellow line: Video Cable</li> <li>White line: Installer Supplied</li> </ul>	<p>DATE: 05/23/2018</p>	<p>Part: Schematic, Sportsman Boats, Group D, 232, 212, 231, 211, 227, 234 Options</p>	
<p>REV: B</p>	<p>REV: A</p>	<p>Part No: 1741-111</p>	<p>Rev: 2</p>
<p>Stock: NONE</p>	<p>Rev: 1 of 2</p>		





# Electrical & Plumbing Systems

## Lights

The NAV/ANC Switch is a 3-position switch on the console that controls the running lights.

- NAV position will turn on the red and green navigation lights and the white all-round light for night driving.
- ANC turns on the all-round light only for night anchoring. Do not operate the boat in anchor position.
- Off is in the center position.

**Sidelights:** The Open 212 has integrated rub rail navigational lights installed at the bow (see figure to the right). A green light is located on the starboard (right) side and a red light on the port (left) side of the vessel. Each shows an unbroken light over an arc of the horizon of 112.5 degrees and is fixed to show from ahead to just behind the beams of the vessel on its respective side.

**All-round/Anchor Light:** This is a white light placed over the highest unobstructed point of the vessel, showing an unbroken light over an arc of the horizon of 360° See the figure to the right for location.

Bow Sidelights

If you have the underwater lights option installed, they can be turned on with the switch at the helm labeled "Accessory 1."

If your boat has a T-Top, the anchor light is located on top of the T-Top at the aft end. With no T-Top, the location is at the stern of the boat as shown here.

Anchor Light if no T-Top

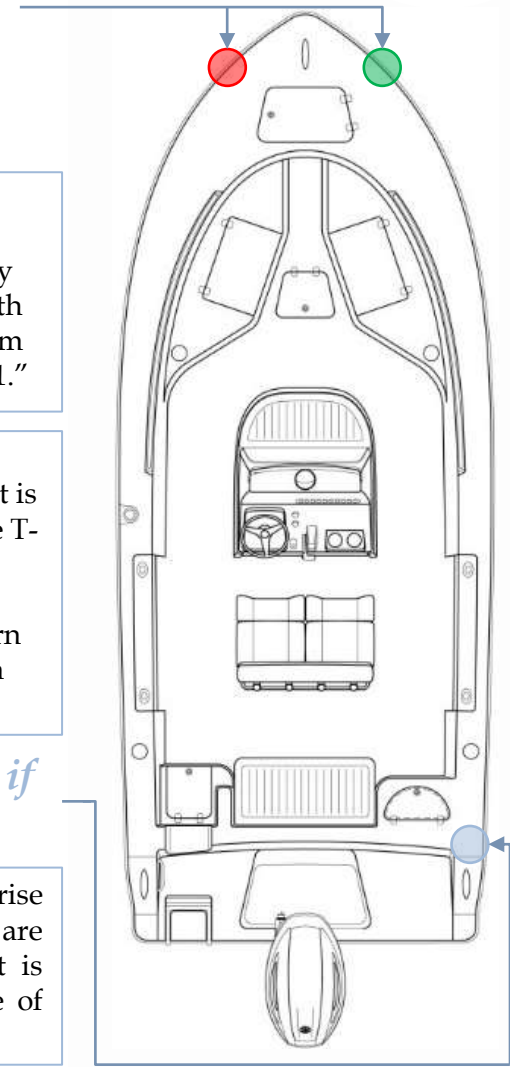

Recreational boats are required to display navigation lights between sunset and sunrise and other periods of reduced visibility (fog, rain, haze, etc.) Navigation lights are intended to keep other vessels informed of your presence and course. Your boat is equipped with the navigation lights required by the U.S. Coast Guard at the time of manufacture. It is up to you to make sure they are visible, operational and turned on.

## Stereo

The Apollo RA670 marine stereo inherits key audio innovations and revolutionary technology from the award-winning Apollo RA770, reimagined in a compact form factor. Built on the True-Marine design philosophy from Fusion®, the Apollo RA670 stereo has an IPX6 and IPX7 rated water resistant front panel and has been tested to a high level of protection against salt, fog, temperature, vibration and UV. Providing uniformity across the helm, the black front face blends seamlessly into black glass panels, complementing other electronics and MFDs for a tidy, uniform and elegant installation.

If your boat has a Fiberglass T-Top, the aft pair of speakers (the left two speakers in the figure to the left) will not be located here. These two speakers will be located on the T-Top underside.



*Speakers*

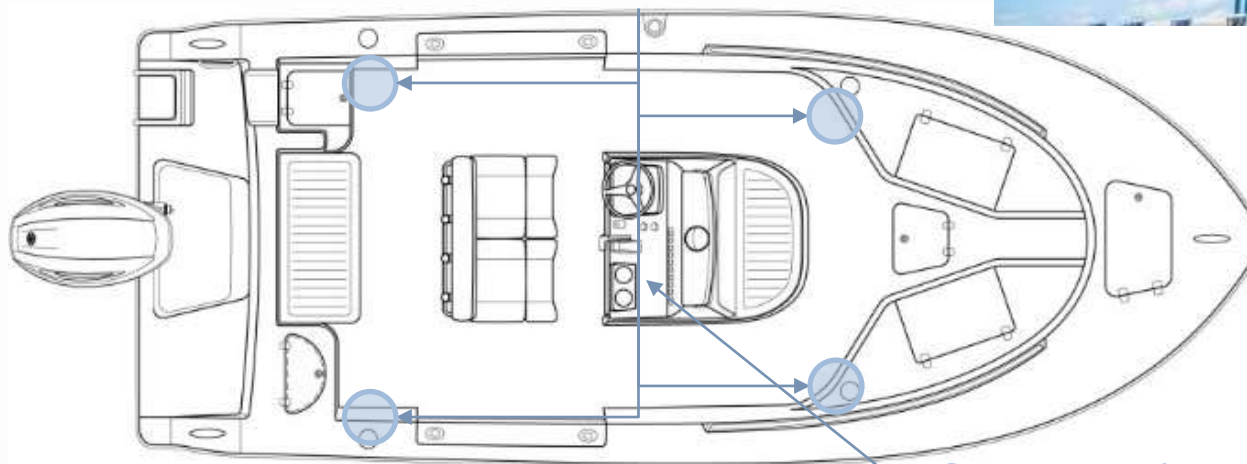

*Source Unit*



# SPORTSMAN

# Electrical & Plumbing Systems



## Stereo Diagram 6 and 4 Chanel DSP AMPS

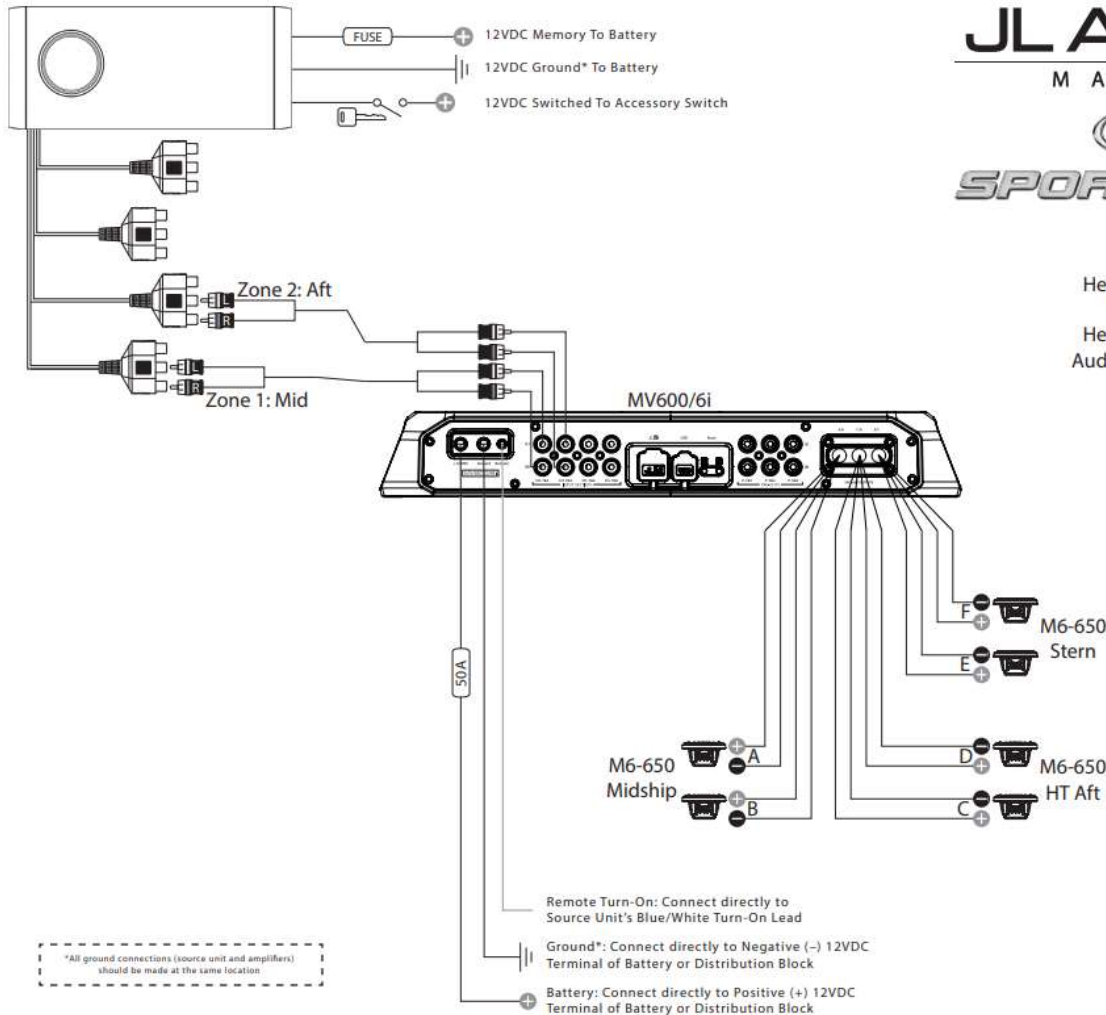

2022  
Open 232 Center Console  
Heritage 231 Center Console  
Open 212 Center Console  
Heritage 211 Center Console  
Audio System Wiring Diagram  
Page 1 of 2

Print on 8.5" x 11" paper.



# Electrical & Plumbing Systems



## Stereo Diagram 6 and 4 Chanel DSP AMPS

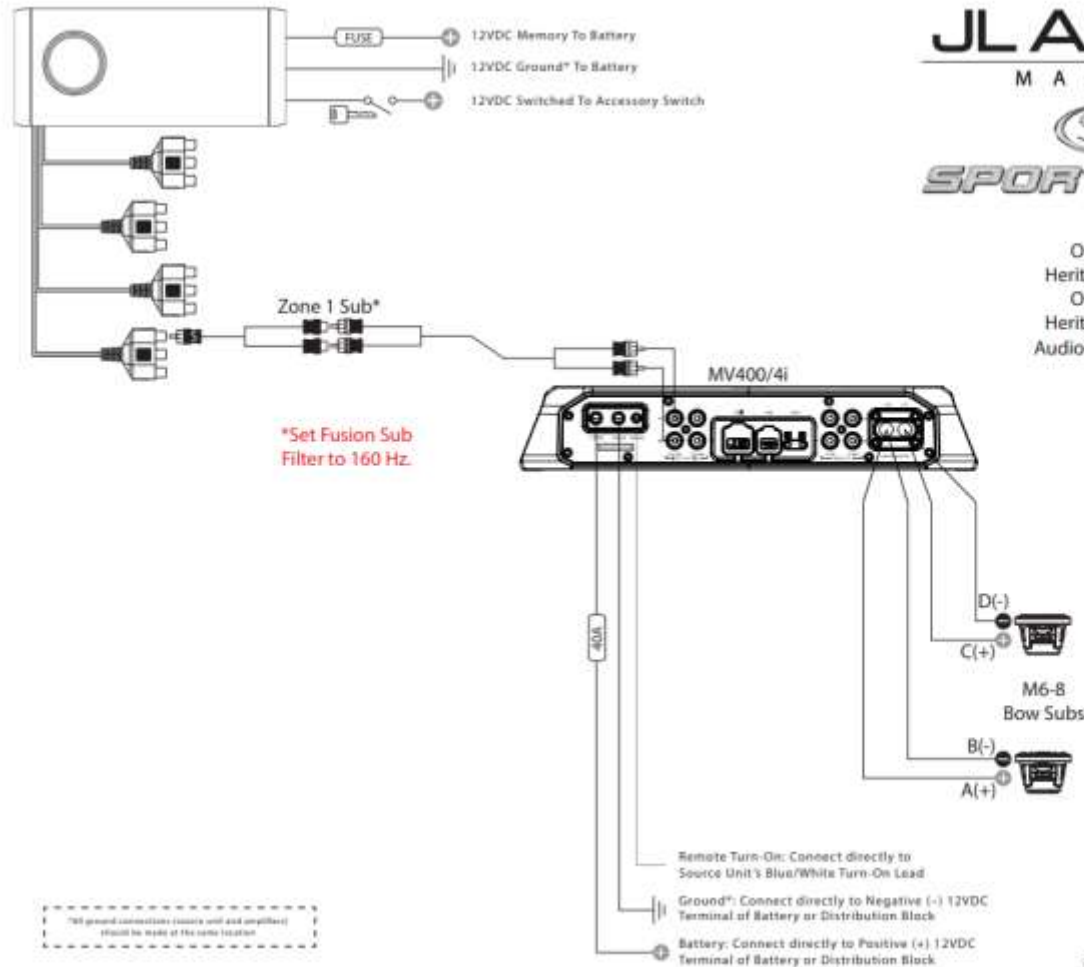

Print on 8.5" x 11" paper.

# Electrical & Plumbing Systems

## 6 + 4 Channel Amp



The NexD2™ full-range technology in this amplifier is DSP-controlled and features a reduced loop area design utilizing DirectFET™ outputs for outstanding fidelity, very low noise and exceptional efficiency. The amplifier chassis is ultra-compact, with all connections on one side, to greatly simplify installation into tight spaces.

Instead of traditional control knobs and switches, all amplifier adjustments and DSP functionality are configured via a compatible external device (PC, Tablet or Smartphone), with the appropriate JL Audio TüN™ Software application installed.

# Electrical & Plumbing Systems



## SEAKEEPER RIDE

*A first-of-its-kind Vessel Attitude Control System (VACS)*

When you are thinking about the new Seakeeper Ride, other products on the market may come to mind. First off, the Ride product line is not a [gyroscopic system](#) like you may have seen on our larger models with the optional Seakeeper. It is designed to be installed in the same location as traditional trim tabs. However, the features of this product far outperform trim tabs and other similar self-leveling systems on the market. Traditional self-leveling trim tab systems simply don't have the speed, technology or sensors required to stabilize. Compared to the Seakeeper Ride, those systems are slow and designed to just level the boat. Having zero capabilities when it comes to smoothing out the ride of the boat underway.

Wave motions can happen consistently or inconsistently, they can be big or small and can come from any direction. Often, these motions occur in just milliseconds. Utilizing Seakeeper Ride's proprietary software and hardware, rapid-deployment rotary blades make 100 adjustments every second to combat wave motions.



**Seakeeper Ride System is the first-of-its-kind Vessel Attitude Control System. This system can eliminate up to 70% pitch and roll underway.**

Seakeeper Ride controllers are mounted to your Sportsman's transom, below the waterline. Using custom, proprietary sensing hardware and software, the system understands how the boat is behaving on all three axes and computes a counteracting sequence to reduce pitch, roll and yaw. As the blades are deployed, they intercept the flow of water off of the transom and create lift, correcting the vessel's motion instantaneously.

# SPORTSMAN

# Electrical & Plumbing Systems

## Bilge Pump

A small bilge pump is located on the hull bottom at the stern of your boat. Water is pumped out of a thru-hull fitting located on the starboard side of the boat near the transom. The pump may be accessed by removing the aft seat and door, in the area shown to the right. You may turn your bilge pump on manually by flipping on your bilge switch located on the switch panel at the helm. Additionally, the bilge pump utilizes a float as an automated switch to turn it on automatically if necessary when the boat is unattended. The bilge pump is designed to remove excess water **only**, and it is **not** intended to stop or prevent rapid accumulation of on-board water due to rough weather, hull damage, or any other unsafe navigational conditions.

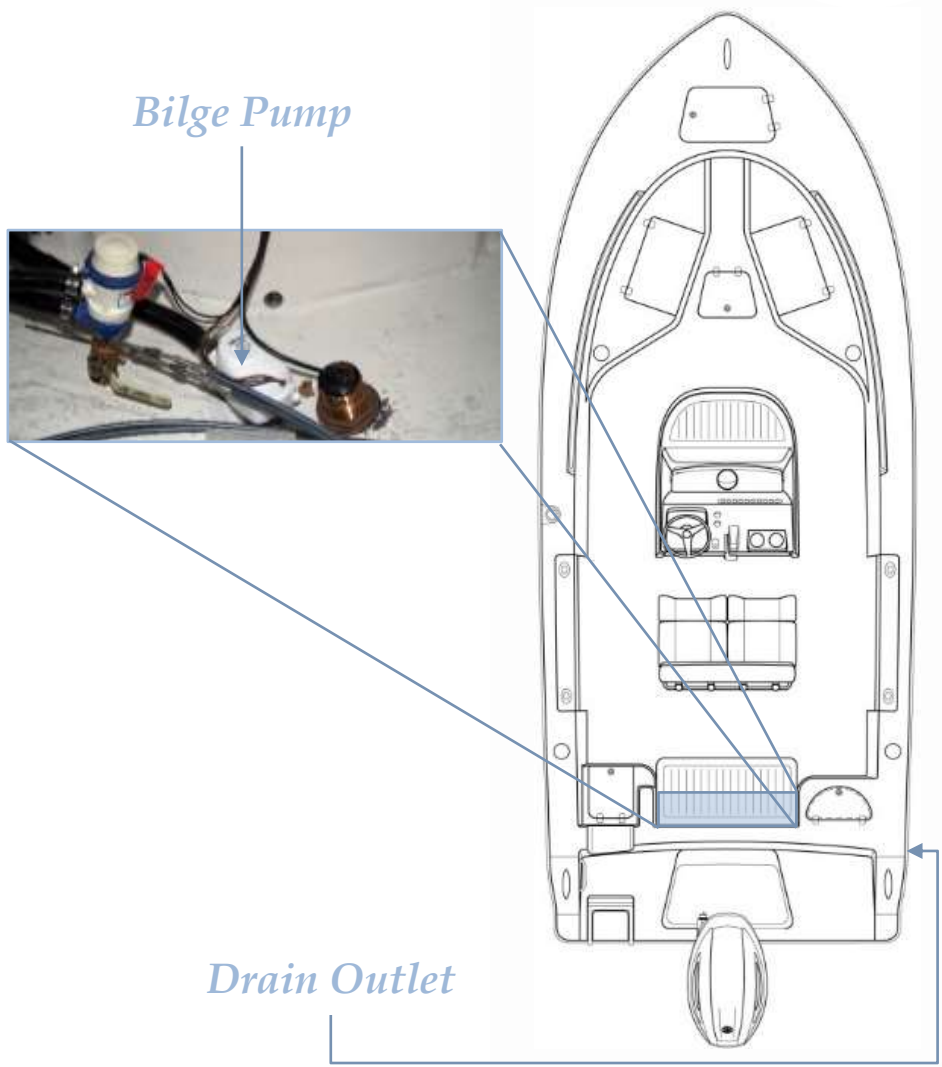

# Electrical & Plumbing Systems

## Livewells

The Sportsman Open 212 comes with a 25 gallon livewell at the starboard stern of the boat. For easy access to the pump and plumbing system, open the total access hatch forward of the transom. The livewell pump is located next to the bilge pump in the hull of the boat, and the livewell fill hose is connected to the top of the pump. To operate the livewell, open the pump valve in the bilge, turn on the livewell switch at the helm, and turn the fill valve in the livewell to "open." The livewell is equipped with an overflow drain so water cannot exceed a certain level and overflow. This overflow drain is connected to the main drain line at a 'T' joint, which empties out an outlet drain at the stern of the boat. Additionally, the livewell has LED lighting installed. To illuminate the livewell, turn on the switch at the helm.

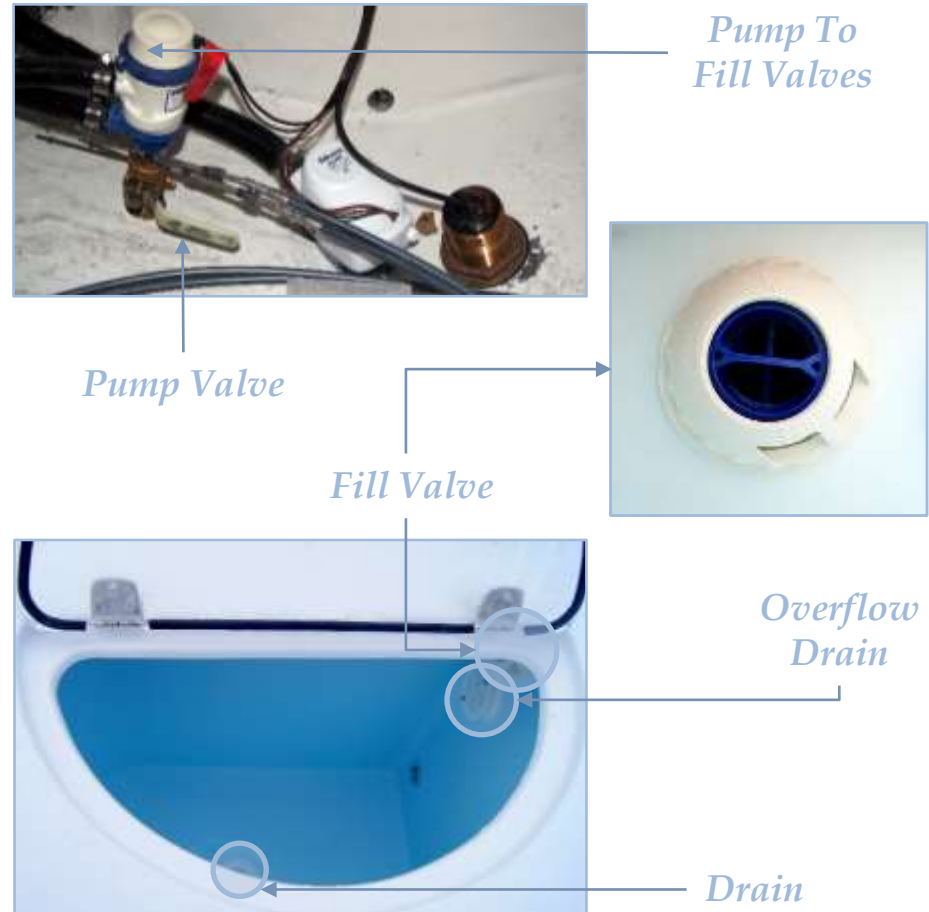



# Electrical & Plumbing Systems

## Raw Water Wash-down

Your Open 212 has the raw water wash-down installed as an standard feature. Rinsing your boat immediately after use with a powerful water jet helps to maintain the boat's condition and value. This system supplies water via a hose connected to bottom of the same pump that supplies water to your livewells with a shut off valve in the bilge area at the total access hatch. To operate the wash-down system, start by opening the valve mentioned above. Then turn on the switch labeled "WASHDOWN" on the switch panel at the helm. The wash-down outlet is found on the starboard side of the boat under the gunwale. See the figures here for important feature locations for the raw water wash-down system.

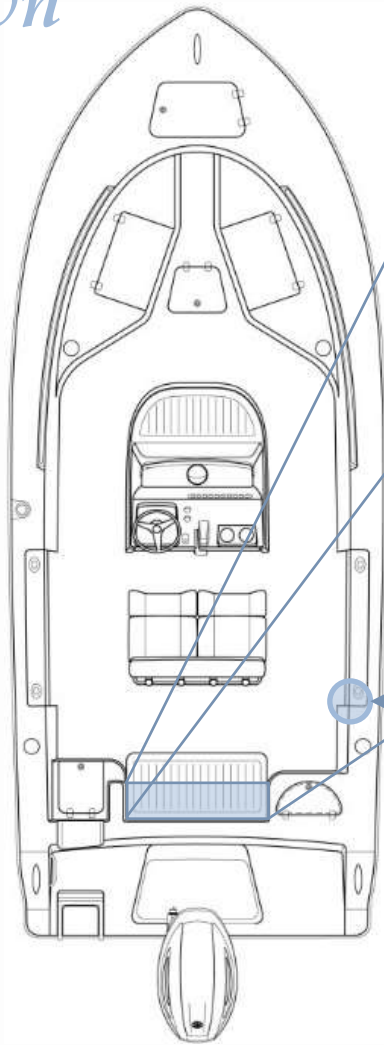

Shut Off Valve

Supply Hose



Outlet

# Electrical & Plumbing Systems



## Fresh Water Wash-down

Your Open 212 may have the freshwater wash-down installed as an option. The freshwater fill fitting and outlet are marked and located on the starboard side of the console. **Do not leave the tank full if your boat will be left unattended for an extended period of time;** pump the tank dry to avoid stagnant water in the tank if necessary. It is also important to periodically inspect and clean the filter, which is located on the pump. The pump is mounted on the inside of the console on the starboard side. To operate this system, turn on the switch labeled "Fresh Water" at the helm. This will pressurize the system for use. When the tank is empty or the boat is not in use, ensure that this switch is in the off position.

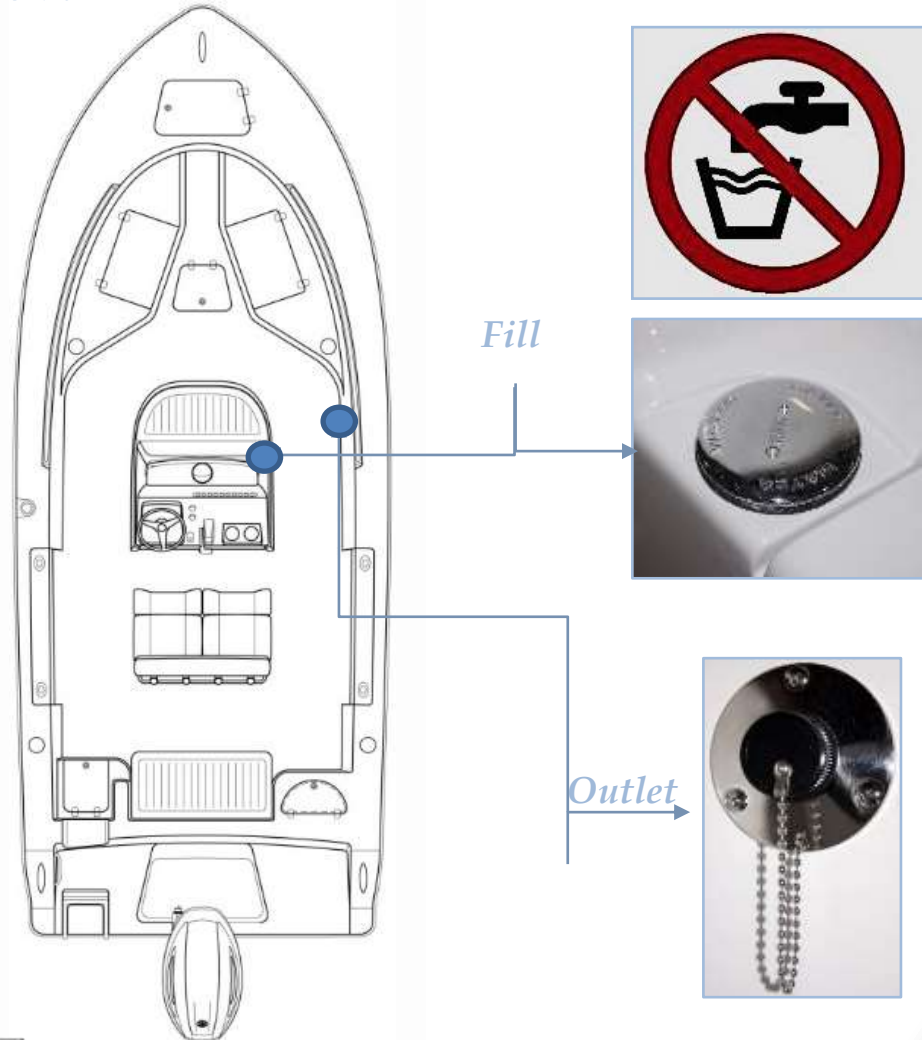

**SPORTSMAN**

# Fuel System

## Fuel Tank

The Sportsman Open 212 comes with a fuel tank installed (61 approximate usable gallon capacity). The gasoline fuel system consists of a fuel tank (located underneath the helm seat as shown in the figure), anti-siphon valve, engine fuel supply line, and fill cap. Your boat contains a new EPA certified fuel system. The system prevents spit-back when filling the tanks and lowers the out gassing emissions through a vent in the new designed fuel fill cap.

*Note: This photo was taken during the assembly process. At this stage, some of the hoses had not yet been connected. In your boat all lines and hoses will be connected as necessary.*

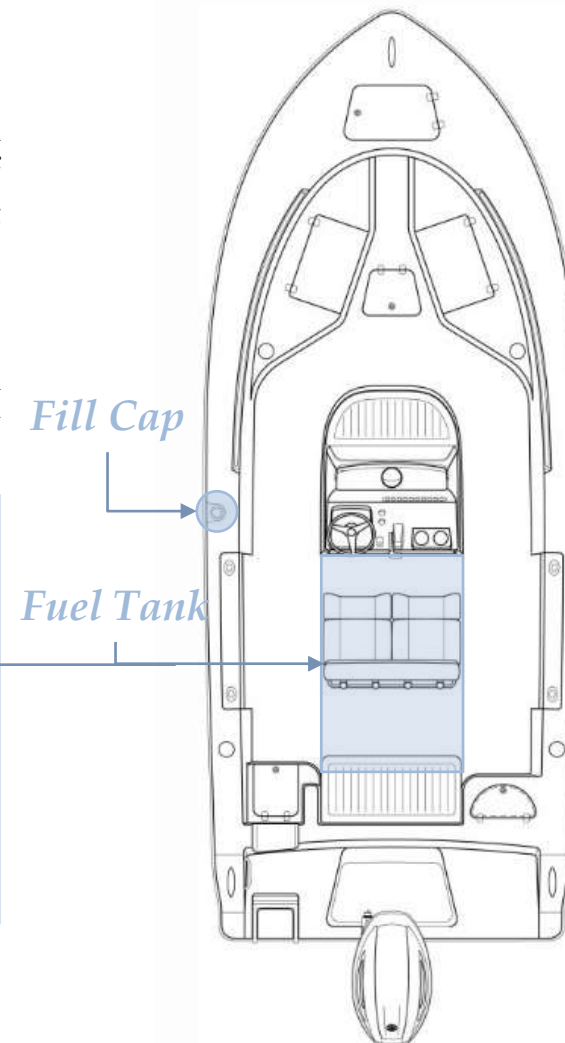
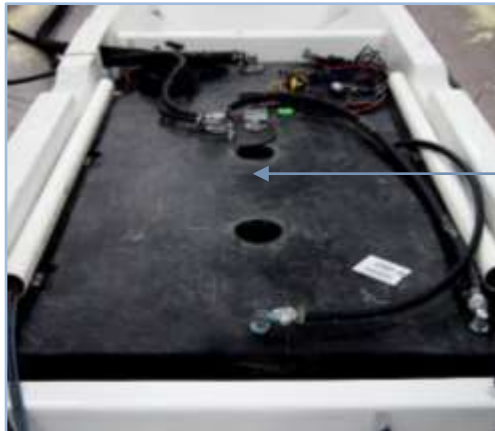

# SPORTSMAN



# Fuel System

## Diurnal Fuel System



**BluSkies**

## EPA DIURNAL FUEL SYSTEMS

**NOTE: Pressure may be present when opening your deck fill, regardless of system type.**



**Only open the fuel cap for refueling**

Note: The first time fuel is introduced to a fuel tank, be aware of the interaction of cold raw fuel vapors replacing air, on occasion a vapor pressure can occur producing spit-back anomalies!

### What is a diurnal fuel system?

Your new vessel is equipped with an Environmental Protection Agency (EPA) compliant diurnal fuel system, designed to reduce fuel emissions to atmosphere using criteria mandated by the EPA. Your vessels fuel tank is required and designed to have a positive pressure (>1PSI) as the sun heats the boat and the fuel in the tank expands or it may be equipped with a carbon canister to catch and contain fuel vapors

Your boats fuel tank also has valves installed inside that are designed to:

1. Produce a clean refueling shut off event
2. Create a 5% vapor space
3. Reduce the propensity of a refueling spit-back event.
4. Allow for appropriate venting when the vessel is stored or trailered. Your fuel cap also contains valves designed to retain fuel vapor (up to 1PSIG) and to allow make up air during engine operation

**SPORTSMAN**

# Fuel System

## Diurnal Fuel System (cont'd)



### Vapor Space (Ullage) And Refueling Management

Another fuel system necessity to remain EPA compliant it is to keep elevated temperature gasoline from expanding into fuel system areas that are not low permeation rated or otherwise sensitive to raw fuel. A vapor (or ullage) space must be produced at the completion of the filling or refueling operation to ensure systems remain EPA compliant during the diurnal temperature cycle. To effectively manage this system function, BluSkies has created a series of valves that can mount to any marine fuel tank to achieve the appropriate fill level while maintaining ullage space of ~5%. Additionally these valves eliminate the propensity for refueling "spit-back" or tank "well-back", which is another requirement of the EPA regulation. BluSkies primary ullage valves replace the existing fill and vent locations, while additional grade or tip level valves can be added to any tank to meet American Boat And Yacht Council standards (H-24) which allows vapor venting for boats slanting or sloping when stored, moored, parked or trailered.

The final decision on which system type and ullage valve type and placement that is best for your application should be based on application specific factors such as type and configuration of fuel tank, how much room there on board is for added components, how are the boats likely to be used and stored etc. and of course cost.

Choose individual components to create a compliant system from the following pages or you can turn to our specialists for sound guidance and direction as you go through the process to choosing the appropriate system for your particular vessel application.

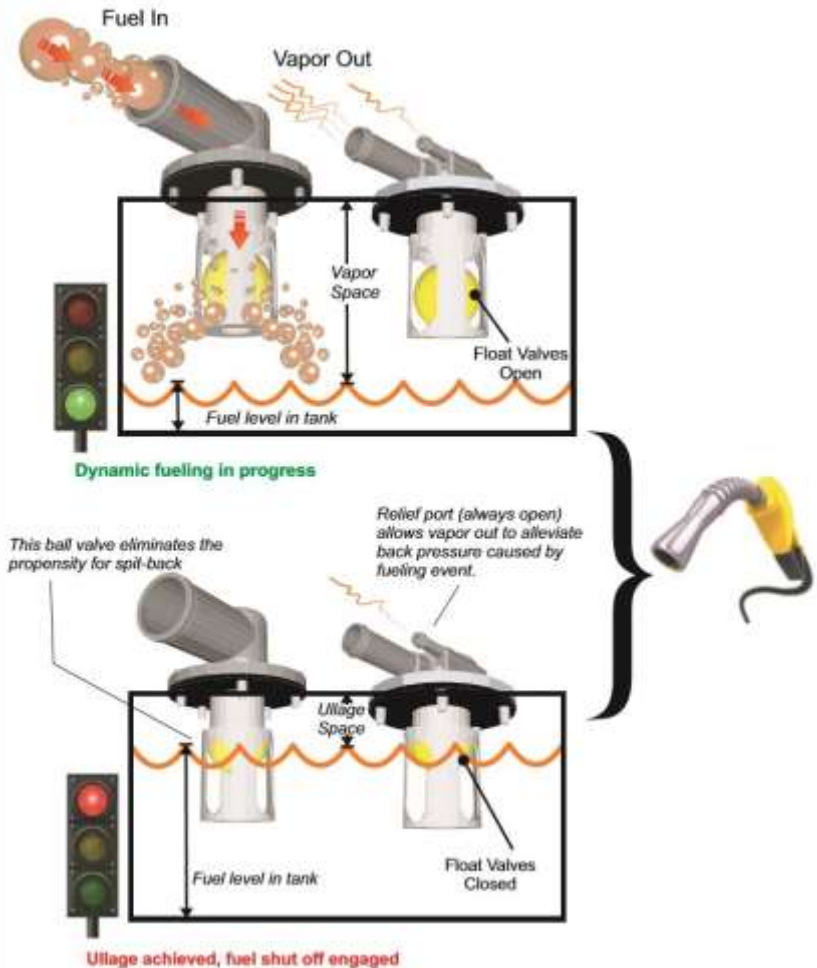

# SPORTSMAN

# Fuel System



## Tank Vapor Space & Fluid Management

### Ullage (Vapor Space) Level Attainment Spit-back/Well-back Control

This vent valve shuts off the refueling vapors and creates back pressure to lift the fill valve ball into place.

This fill valve ball is set lower than the vent valve ball but does not close until the refueling vapors are shut off by the vent valve.

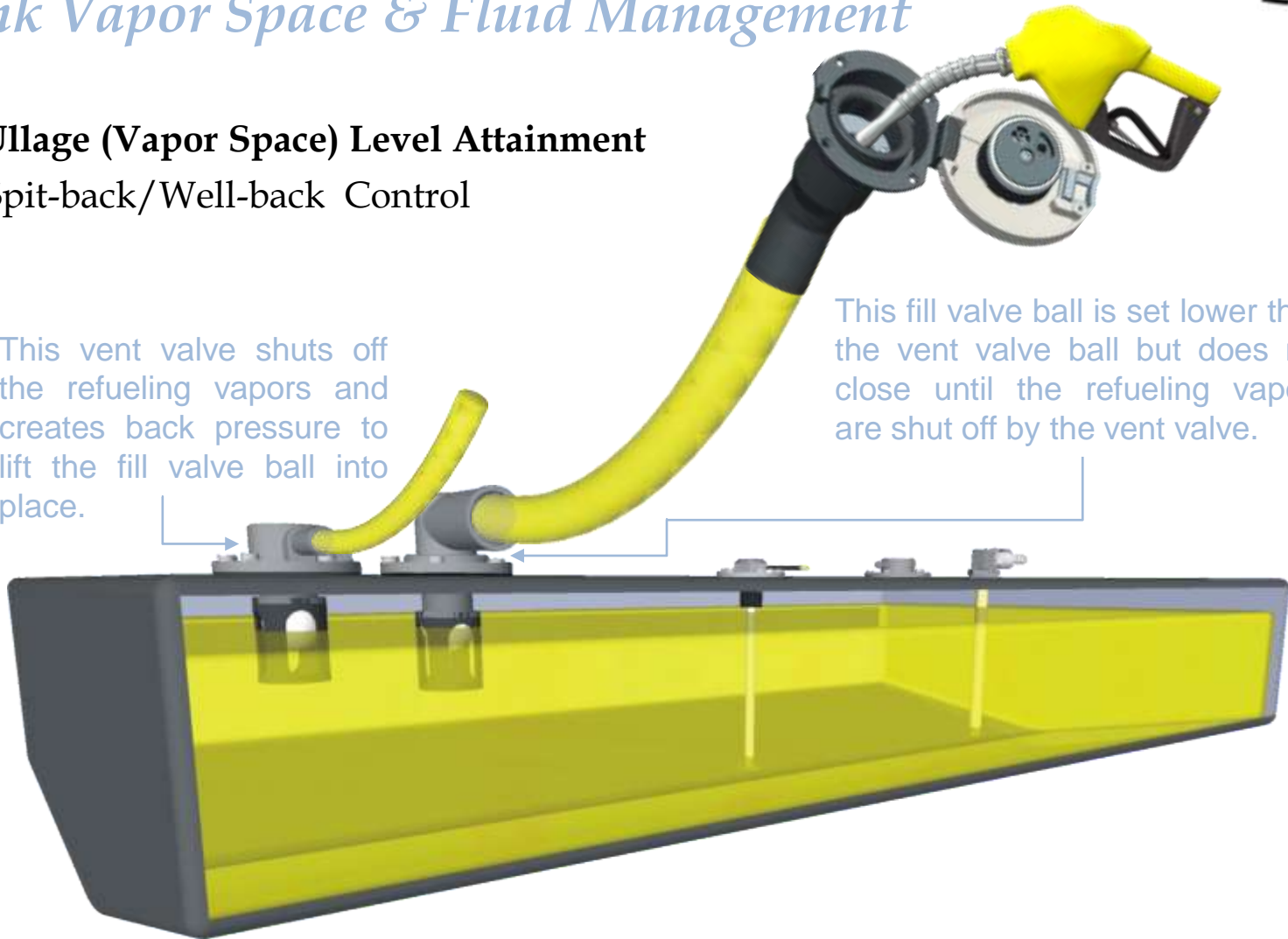

**SPORTSMAN**

# Fuel System

## Diurnal Fuel System: Refueling



Your fuel tank capacity will vary from the label or published capacity no less than 5% by law and up to 10% dependent upon the variation from static float due to equipment, occupants and gear etc. (Static Float = attitude in which your boat floats in calm water)

**Fill your vessel fuel tank as normal, stop refueling after two (shut off) clicks of the fuel nozzle.**

Topping off will over ride your fuel system design intent and could cause damage to your vessel due to overflow and will void any and all warranty claims related to fuel spillage.

BluSkies is expressly not responsible for any damage to your vessel subsequent to topping off.

### WARNING

CONTENTS CAN BE UNDER PRESSURE  
AVOID SERIOUS INJURY OR DEATH FROM  
FIRE OR EXPLOSION  
OPEN SLOWLY IN WELL VENTILATED AREA  
NO SMOKING OR OPEN FLAMES

It has been a common practice for many years to top off boats prior to storage or in preparation for a day on the water, however diurnal fuel systems are designed specifically to leave a space in your fuel tank to allow the fuel to expand during the heat of the day. GASOLINE EXPANDS 5%.

### REFUELING

GASOLINE CONTENTS UNDER PRESSURE. FUEL SPRAY MAY OCCUR.

1. OPEN CAP SLOWLY
2. INSERT FUEL NOZZLE
3. BEGIN & CONTINUE FUELING UNTIL FUEL NOZZLE KICKS OFF
4. WAIT 10 SECONDS & CONTINUE FUELING UNTIL NOZZLE KICKS OFF A SECOND TIME
5. RETURN NOZZLE TO PUMP
6. DO NOT TOP OFF

# Boating Navigation Rules



There are three main situations that you may encounter with other vessels which could lead to a collision unless the Steering Rules are followed:

- Meeting**: you are approaching another vessel head-on
- Crossing**: you are travelling across the path of another vessel
- Overtaking**: you are passing or being passed by another vessel

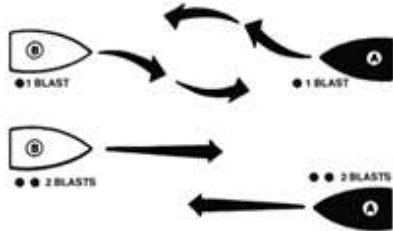

**When Meeting Port-to-port:** Continue on course. The same holds true for meeting starboard-to-starboard.

**When Meeting Head On:** As in a car, both stay to your right and as far apart as practical. Each boat should turn to starboard and pass port-to-port.

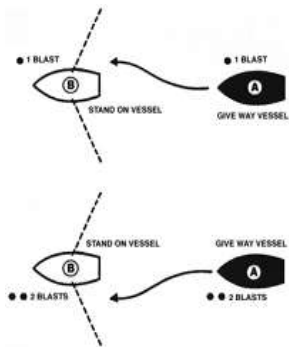

**When Crossing:** Every boat has a "Danger Zone" from straight in front (the bow) to past the middle of its right side. Like when meeting another car at a street intersection, the one on the right has the right of way. You must yield to boats in your Danger Zone. If you are the skipper of the Vessel A in the center of the diagram, you must keep out of the way of any boat that approaches you from any direction within the indicated Danger Zone, as you are the burdened craft. Likewise, boats approaching you from all other directions, except the meeting vessel, must keep clear of you.

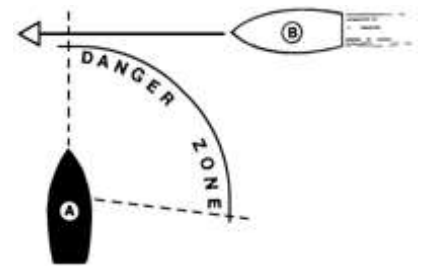

**When Overtaking Another Boat:** The boat being overtaken is the privileged vessel. Only after signaling and receiving an acknowledgment can the overtaking boat pass. (Use one blast to pass on the right, and two blasts to pass on the left.)

**When Being Overtaken:** Be ready for trouble when a power boat passes you in a narrow waterway. As the lead boat, which always has the right of way, stay on your side of the channel and maintain a steady speed so that the overtaking vessel can pass you safely. Use your radio to discuss this with the passing boat.



## *Product Changes*

Sportsman is committed the development of our product line. As a result, equipment described in this manual may have changed or no longer may be available. All information, illustrations and specifications contained in this manual reflect the latest product information available at the time of publication. Sportsman reserves the right to make changes to its boats at any time, without notice. These changes include, but are not limited to: color options, materials, standard and optional equipment, specifications and model availability. If you have any questions about the equipment on your boat, please feel free to contact Sportsman.

## *Insurance*

In most states, the boat owner is legally responsible for damages or injuries they or anyone else operating the boat causes. Some states have laws that require having at least minimum coverage. Before using your boat for the first time, you should contact your dealer, current insurance company, or state boating authority for information regarding insurance requirements in your area. Although it may not be required in your area, responsible boat owners carry liability and property damage for their boat. You should also protect the boat against physical damage and theft.

## *Service*

All warranty work must be performed by an authorized Sportsman Dealer. If a problem is discovered upon taking delivery of, or develops during routine use of the boat that is related to faulty workmanship and/or materials, as stated in the warranty, you need to contact your Sportsman dealer to arrange for your boat to be repaired. **The boat owner is responsible for delivering the boat to the dealer for warranty service.** If you are not near your dealer or any other authorized Sportsman dealer, please contact Sportsman. Likewise, if the dealer fails to repair the problem, please notify Sportsman within 14 days of the work being completed. **Sportsman will not reimburse owners for unauthorized warranty work.**

# Warranty and Services



## SPORTSMAN BOATS LIMITED WARRANTY

**Ten-Year Hull Limited Warranty:** This limited Warranty applies to any Structural Hull Defect (as that term is defined below) if such is due to a failure in material or workmanship and the was reported to Sportsman according to the terms of this Limited Warranty within ten (10) years from the date of the sale to the original purchaser of the Sportsman authorized dealer. Sportsman, in its sole discretion, will either repair or replace the Hull. For purposes of this Limited Warranty, the term “Hull” shall mean the single fiberglass molded shell and integral structural components of a Sportsman Boat, and the term “Structural Hull Defect” shall mean a substantial defect in the Sports Boat’s Hull that causes the boat to be unfit or unsafe for general use as a pleasure craft under normal operating conditions.

**One Year Nonstructural Limited Warranty:** This Limited Warranty applies to any Nonstructural Defect (as that term is defined below) if such is due to a failure in material or workmanship and the same was reported to Sportsman according to the terms of this Limited Warranty within one (1) year from the date of the sale to the original purchaser of the Sportsman Boat by a Sportsman authorized dealer. Sportsman, in its sole discretion, will either repair or replace the defective component. For purpose of this Limited Warranty, the term “Nonstructural Defect” shall mean a substantial defect in a Sportsman Boat’s components manufactured or installed by Sportsman (other than the Hull) that is not excluded in the exclusions below.

**Registration and Transfer of Limited Warranty:** Each original purchaser of a Sportsman Boat shall complete and return the boat registration card provided by Sportsman within thirty (30) days of such owner’s purchase of the boat in order to facilitate the processing of warranty claims and for manufacture notification. Except where a Sportsman Boats has been salvaged and resold after a declaration of a total loss or a total loss or a constructive total loss, this Limited Warranty is transferrable to a subsequent owner of the Sportsman Boat. PROVIDED SUCH SUBSEQUENT OWNER FILL OUT AND SEND TO SPORTSMAN A SPORTSMAN WARRANTY TRANSFER FORM (AVAILABLE FROM SPORTSMAN ON REQUEST). A COPY OF THE BILL OF SALE, WHITHIN THIRTY (30) DAYS OF SUCH TRANSFER OR PURCHASE.

# SPORTSMAN

---

# Warranty and Services



## SPORTSMAN BOATS LIMITED WARRANTY (cont'd)

### EXCLUSIONS:

This limited Warranty does not apply to any boat that has been salvaged or declared a total loss or constructive total loss for any reason not specifically covered in this Limited Warranty. In addition, this Limited Warranty does not apply to the following "Exclusions:"

- 1) A Hull, component, or other product that has been repaired without authorization of Sportsman or that has been altered in any way that affects its use and operation;
- 2) Expenses related to inspection or warranty service for hauling out, transportation to and from any dealer or Sportsman factory, towing or storage charges, inconvenience or loss of time or income;
- 3) Engines, outdrives, controls, propellers, engine brackets, stereos, depth finder, GPS units, trolling motors, batteries, outriggers bases' and other equipment or accessories that are not manufactured by Sportsman, whether the same is or is not warranted by such other manufacturer;
- 4) Blistering, discoloring, cracking, or crazing of the Gelcoat finish or other surface finishes
- 5) Any Sportsman Boat initially sold at retail by a party other than an authorized Sportsman dealer;
- 6) Damage to, breakage of, or leakage around any windshields, hatches, or apertures;
- 7) Any canvas, zippers, vinyl, upholstery, plastic, or fabric components;
- 8) Discoloration, oxidation, bleeding, or corrosion of any stainless steel or other metal products
- 9) Any Hull, component, or product that has been subject to unreasonable use, tampering, abuse, mishandling, improper maintenance, negligence, improper trailing, alterations, or accidents;
- 10) Any boat, or component or part thereof, that has been used for Commercial Purpose, racing purposes, or has otherwise been operated contrary to any printed instruction provided by Sportsman or contrary to any applicable law (for purposes of this Limited Warranty, the term "**Commercial Purposes**" shall mean the usage of any boat more than fifty percent (50%) for revenue-producing or other business purposes);
- 11) A boat, or component or part thereof, that has been overpowered according to the maximum recommended engine horsepower specified on the capacity plate attached to the boat;
- 12) Machinery, equipment and accessories not installed by Sportsman;
- 13) Condensation of gauges;
- 14) The failure of any part, area, or component of the boat to be dry, whether or not the same was represented as "dry";
- 15) Any representation relating to the speed or weight of any part or component of the boat;
- 16) Normal wear and tear maintenance items, including, but not limited to, filters bulbs, batteries, bungees, anchor rope, trailer finishes, tires, brakes, bearing, and lights;
- 17) Any defect or repair requiring redesign of the boat, except pursuant to the recall provisions of the United States Federal Boat Safety Act of 1971 or the recall laws of the recall laws of any other foreign jurisdiction;
- 18) Dealer preparation, cleaning, and final adjustments and alignments in preparing the boat for delivery or commissioning; or
- 19) Any act of God or force majeure.

# SPORTSMAN



Thank you for your purchase of your Sportsman Boat.

Sportsman Boats Manufacturing, Inc.  
113 Sportsman Way · Summerville, South Carolina 29483  
Telephone (843) 376-2628 · Fax (843) 376-2636

Email

*sales@sportsmanboatsmfg.com*

Website

*www.sportsmanboatsmfg.com*



***SPORTSMAN***